

DECK RIDGE

UPPER BOW PIECE

LOWER BOW
KEELSON

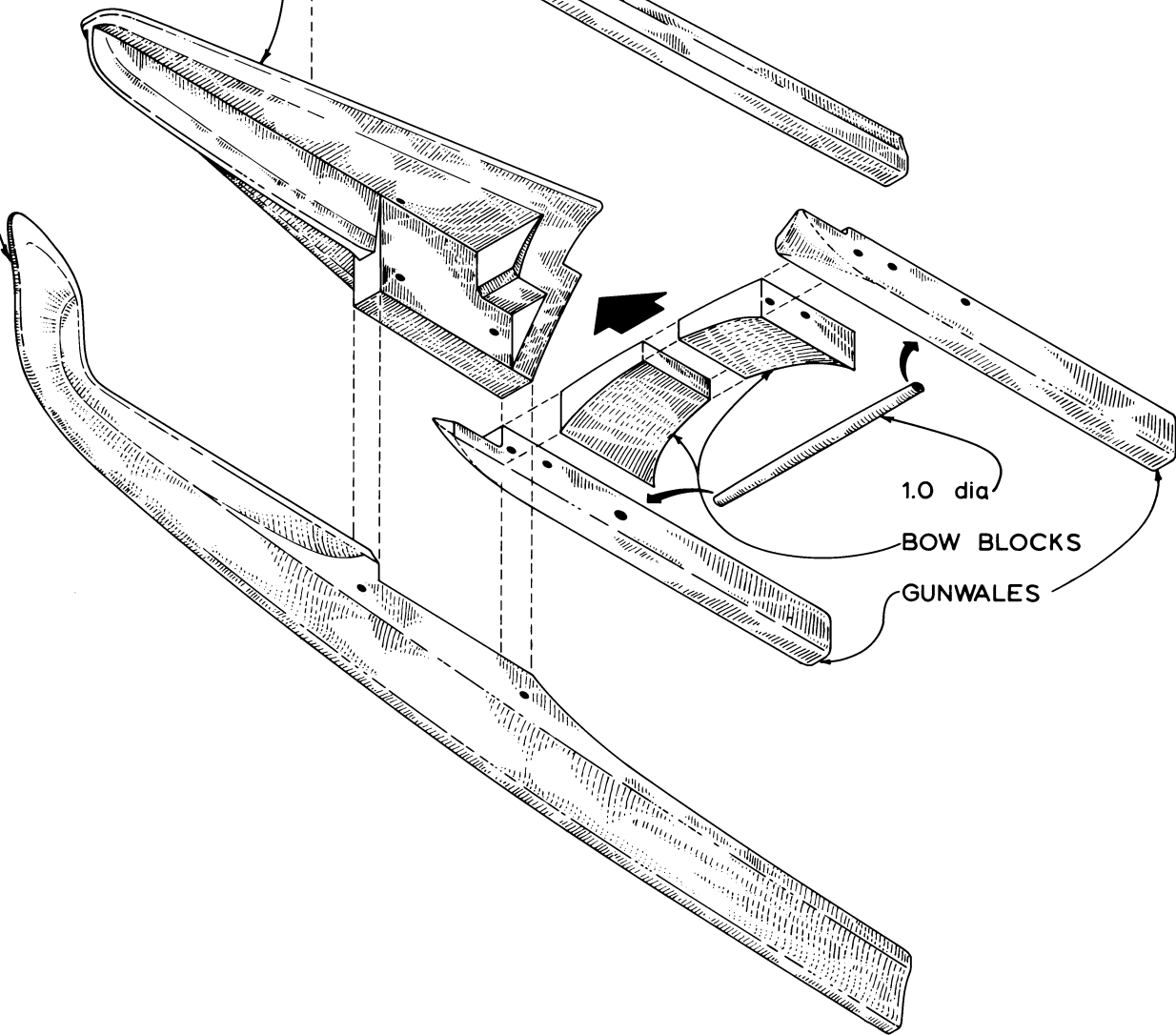

1.0 dia

BOW BLOCKS

GUNWALES

BOW CONSTRUCTION

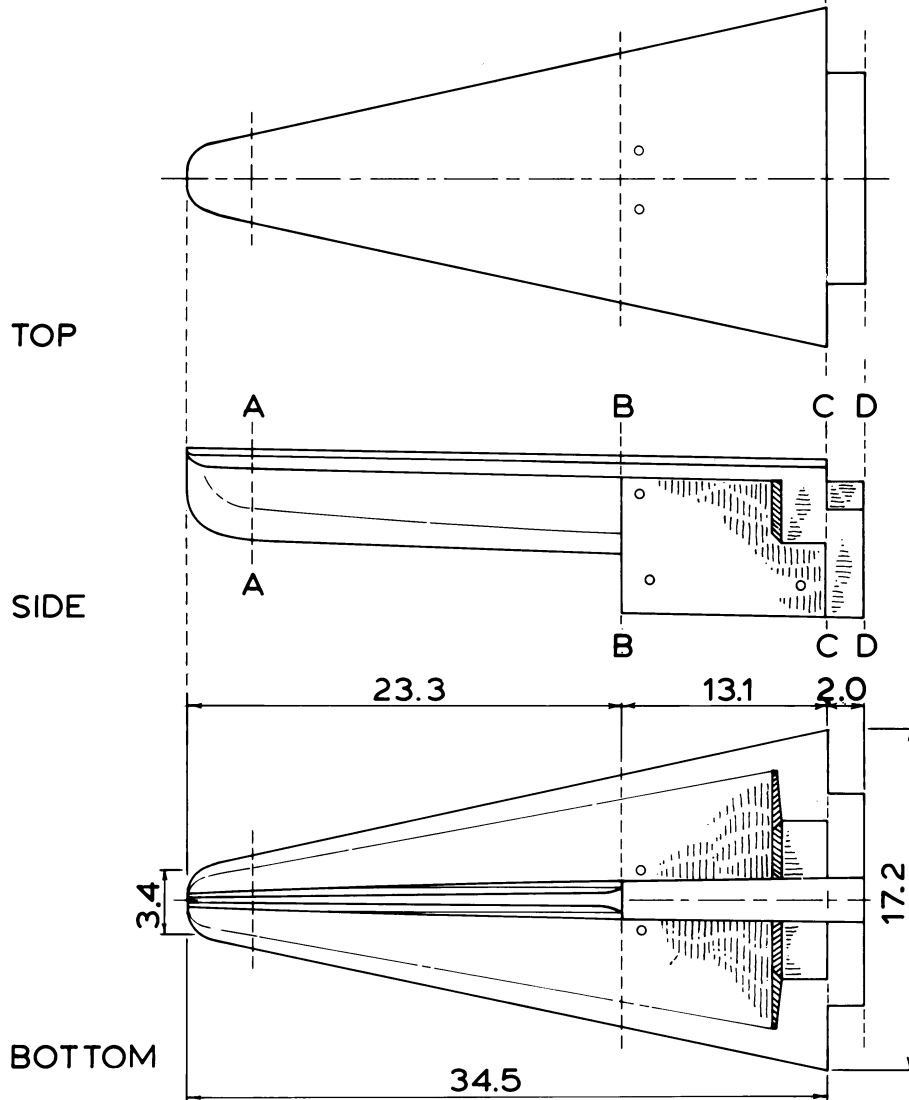

SECTION A-A



SECTION B-B

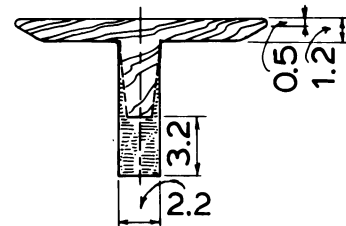

SECTION C-C

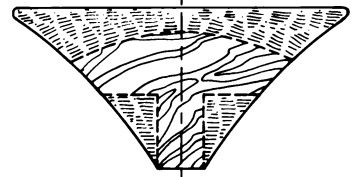

END VIEW DD

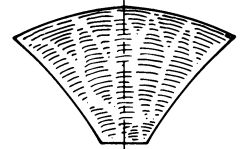

UPPER STEM PIECE

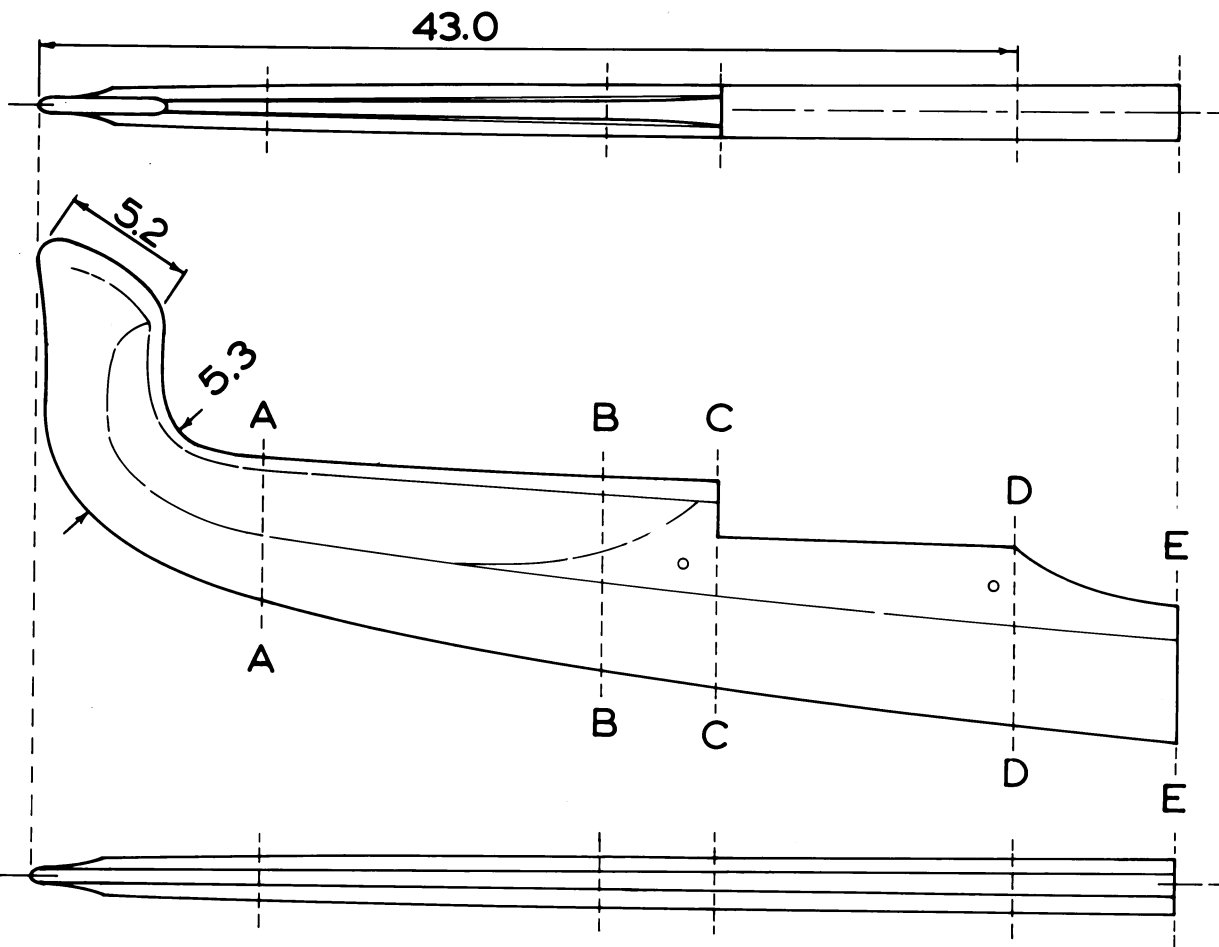

SECTIONS

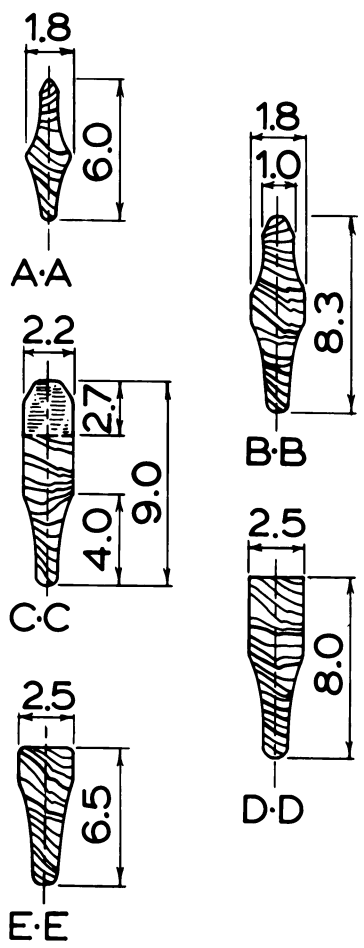

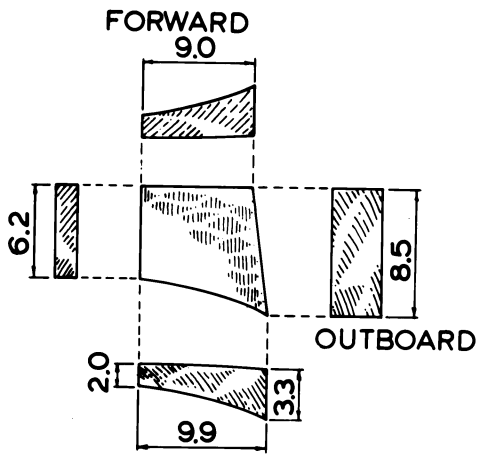

BOW BLOCK (2)

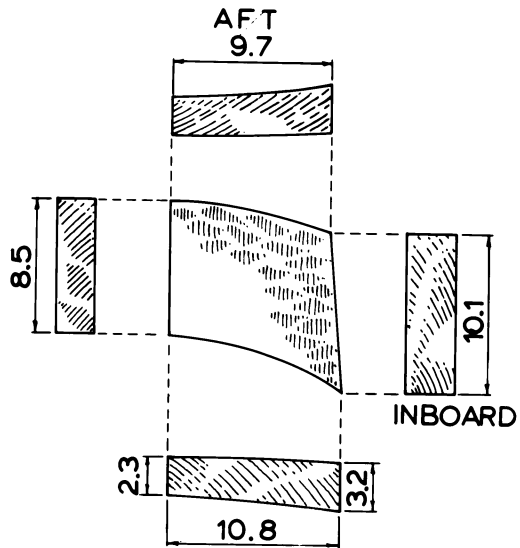

STERN BLOCK (2)

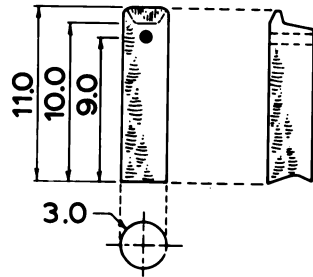

COCKPIT STANCHION (2)

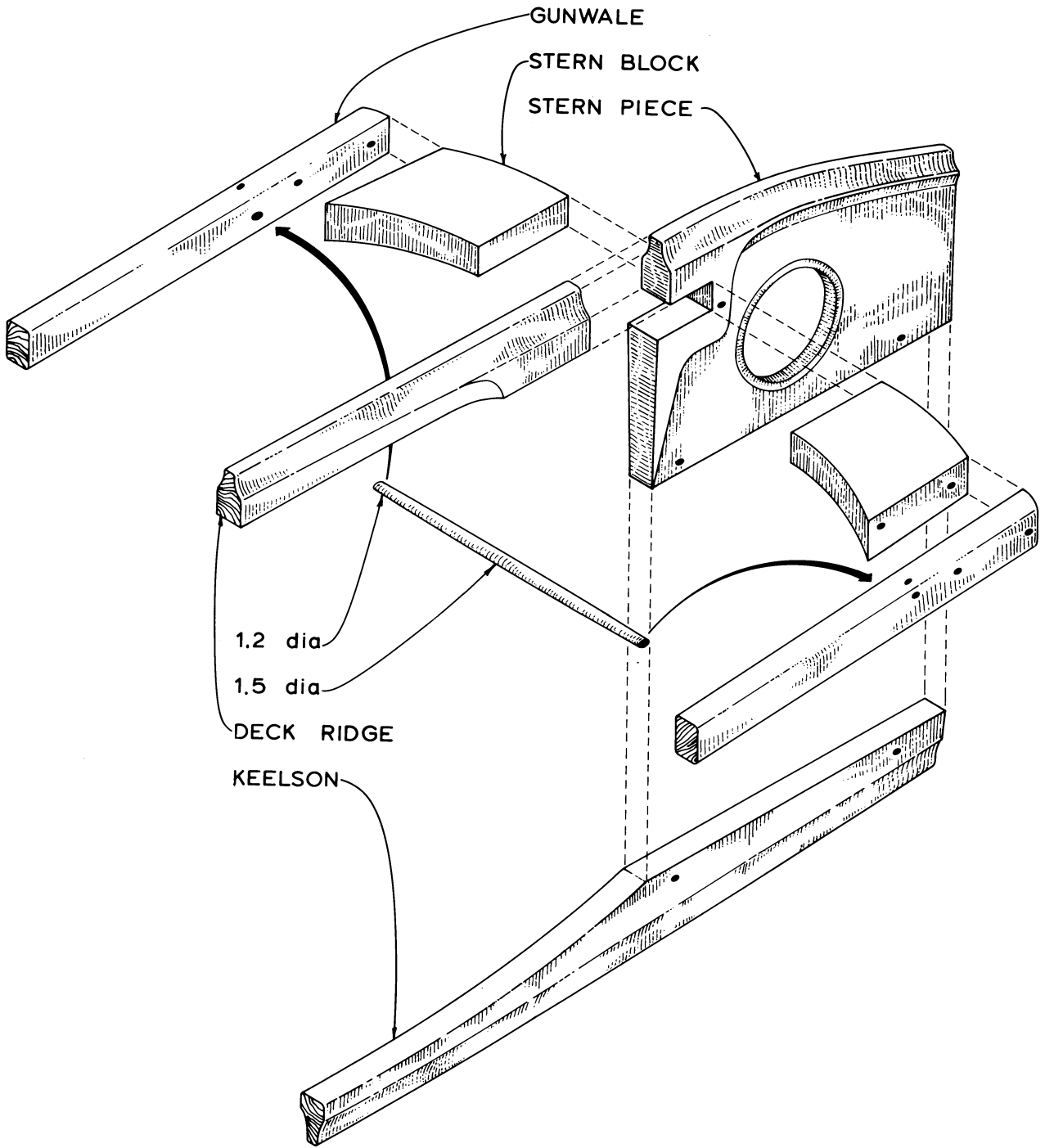

STERN CONSTRUCTION

28.0

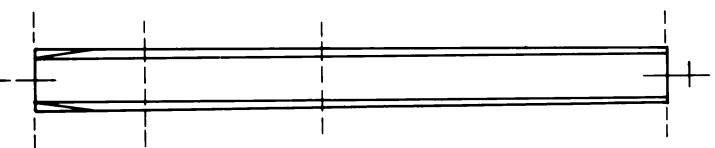
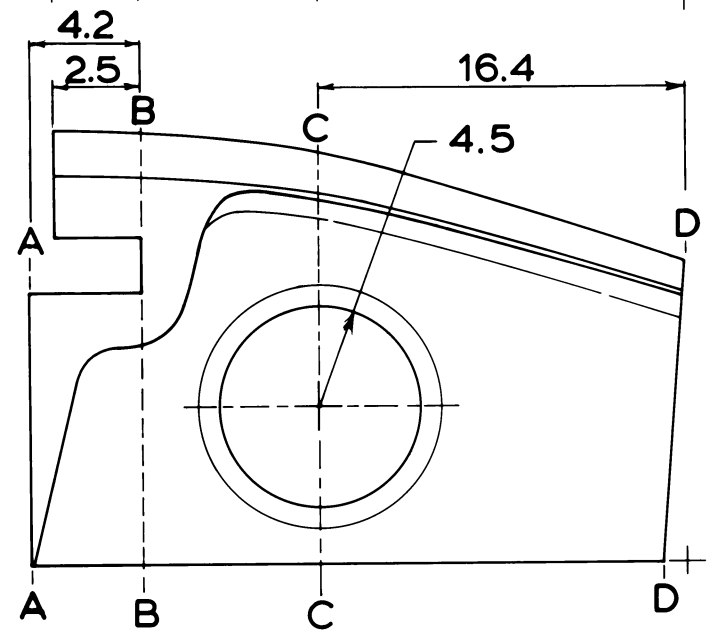
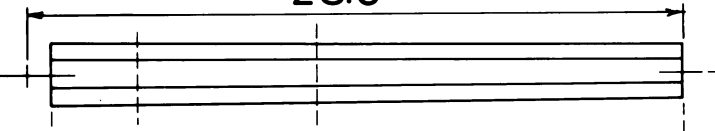

SECTIONS

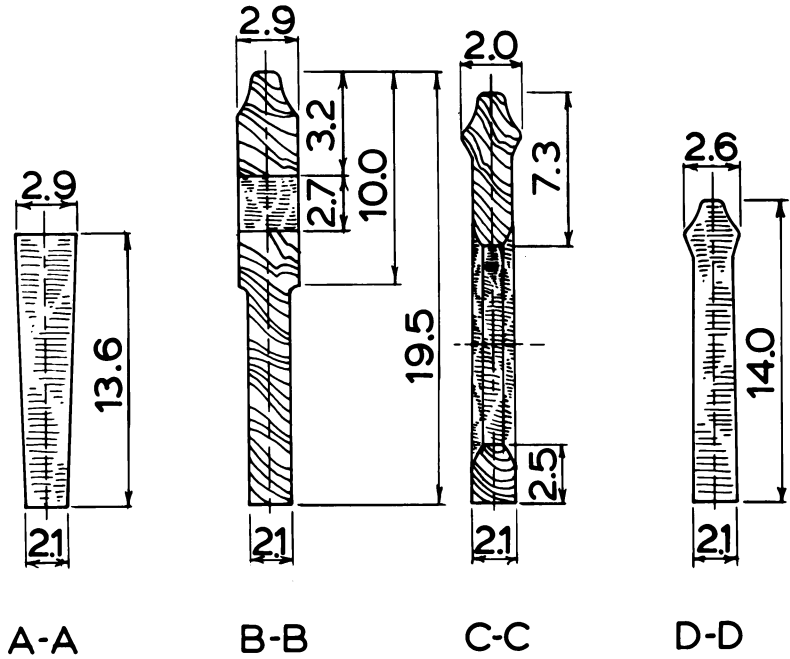

STERN PIECE

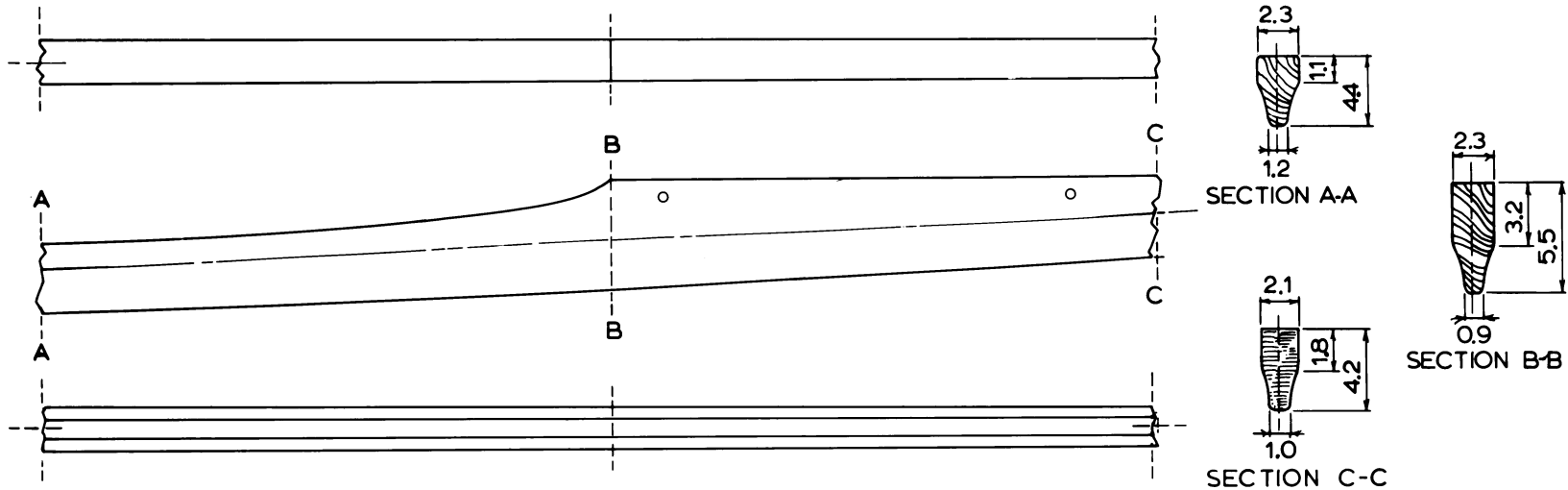

STERN KEELSON PIECE

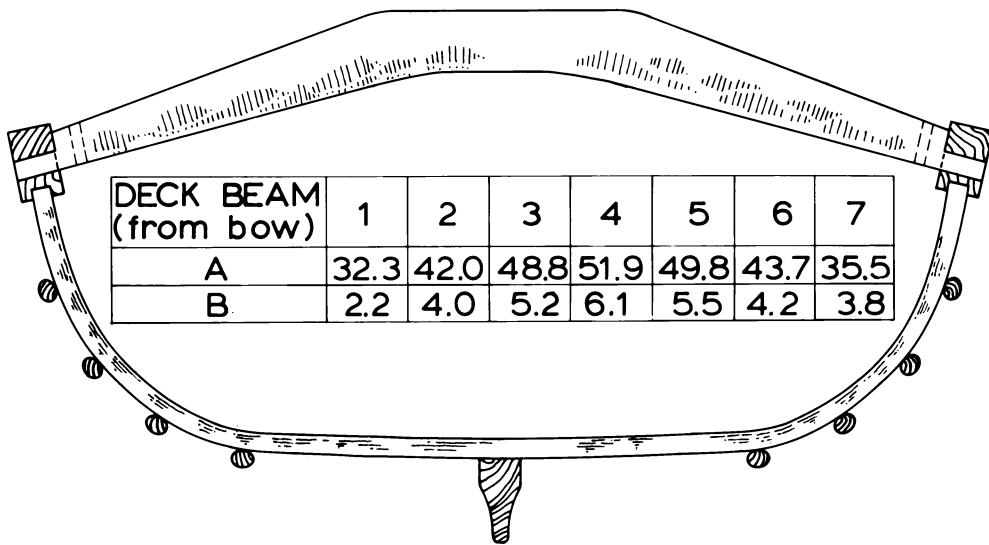
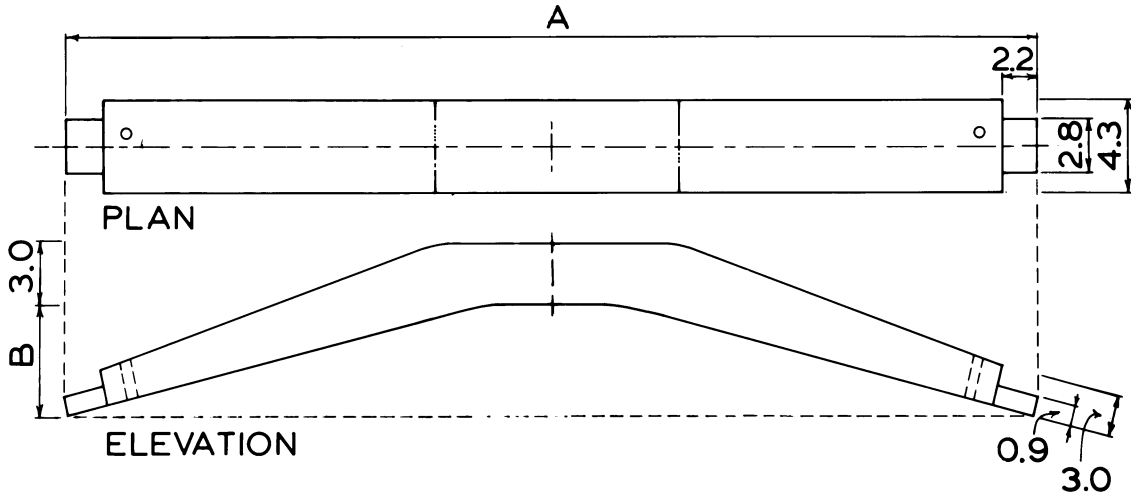

DECK BEAMS

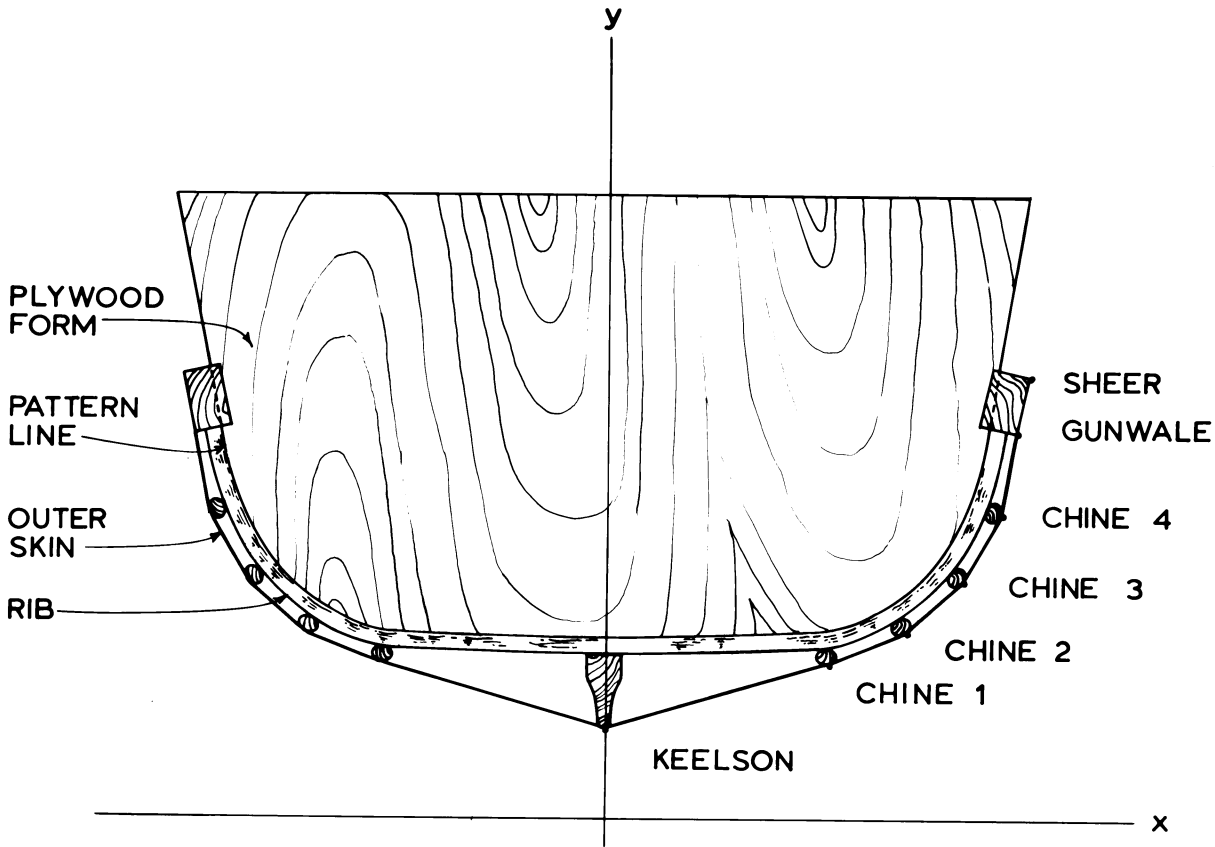

STATION 6

STATION 6	x	y
SHEER	25.8	24.6
GUNWALE	25.2	21.2
CHINE 4	24.0	16.2
CHINE 3	21.8	12.2
CHINE 2	18.2	9.0
CHINE 1	13.6	7.2
KEELSON	0.0	3.3

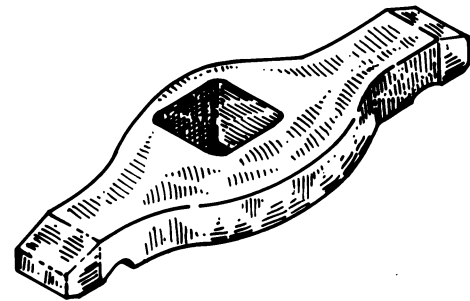
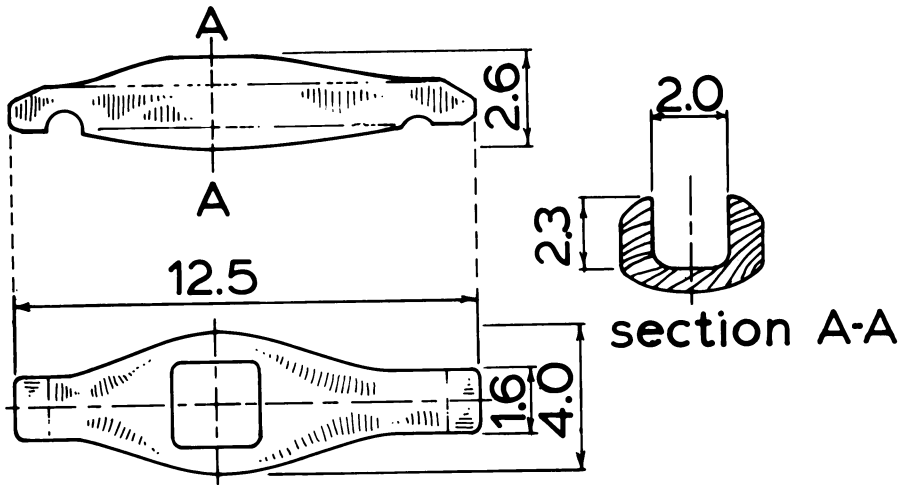

MAST STEP
located between ribs 11 and 12

DECK STRINGER

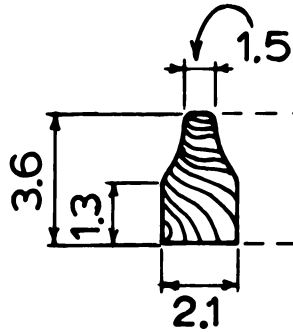

COCKPIT COAMING

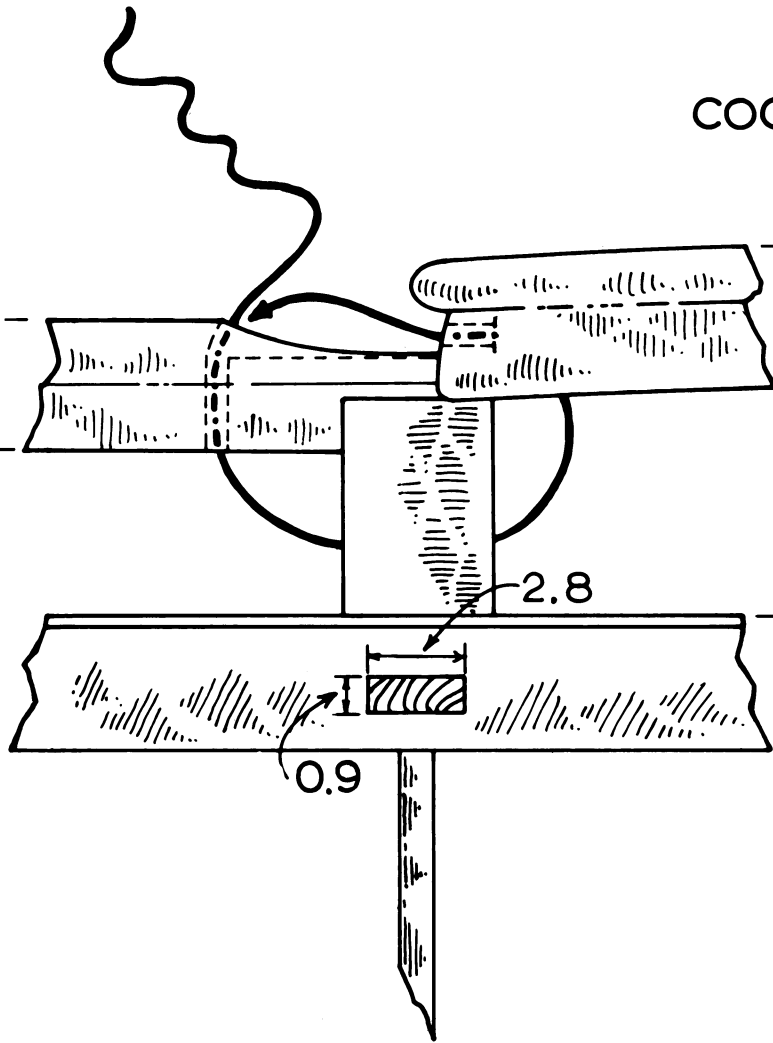
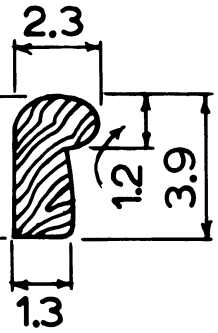

0.9

2.8

GUNWALE

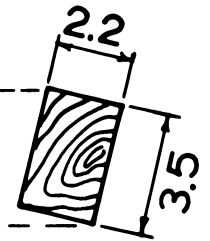

DECK BEAM / DECK STRINGER / COAMING LASHING

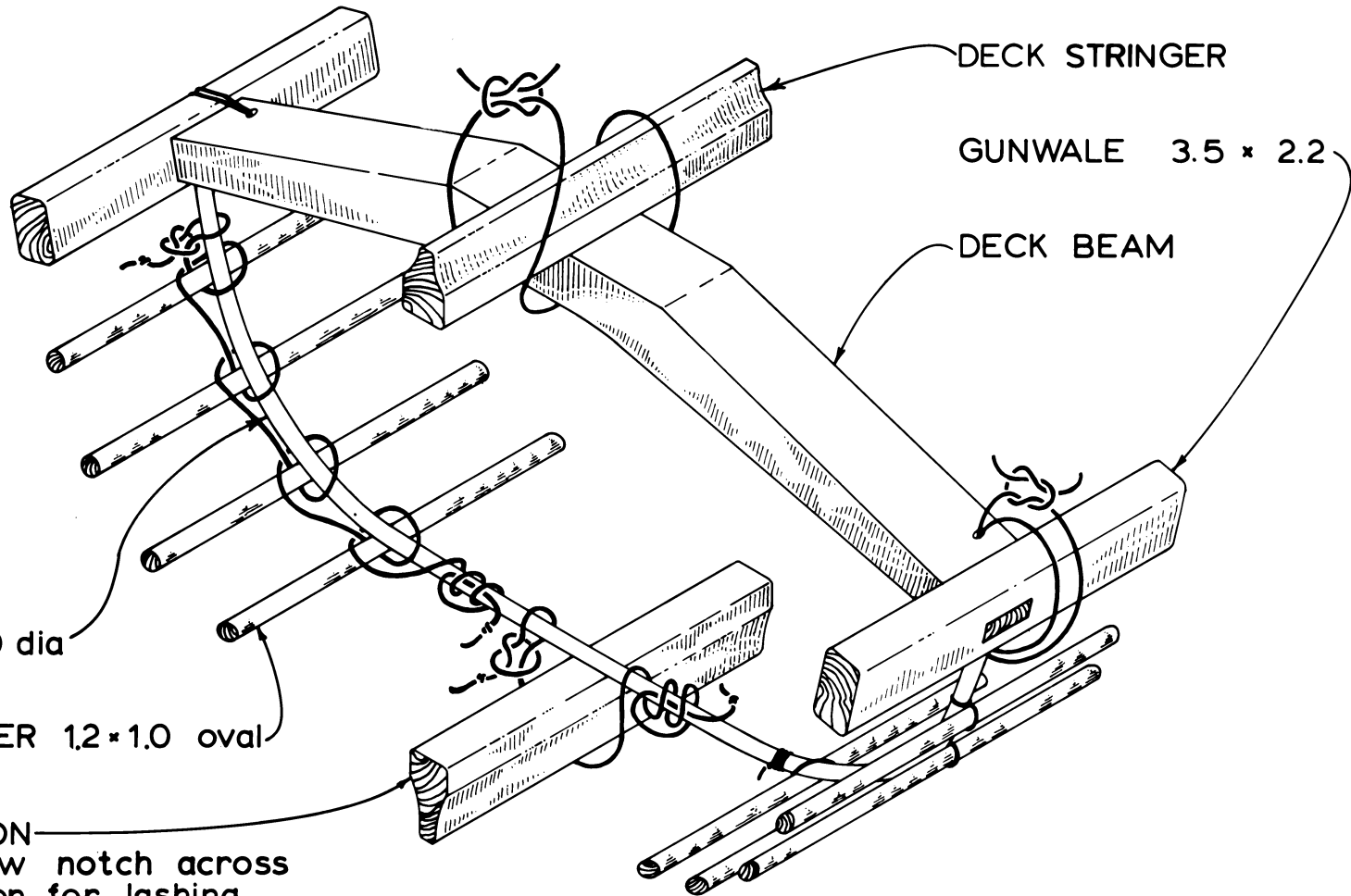

DECK STRINGER

GUNWALE 3.5 x 2.2

DECK BEAM

RIB 1.0 dia

STRINGER 1.2 x 1.0 oval

KEELSON
shallow notch across
keelson for lashing

LASHINGS

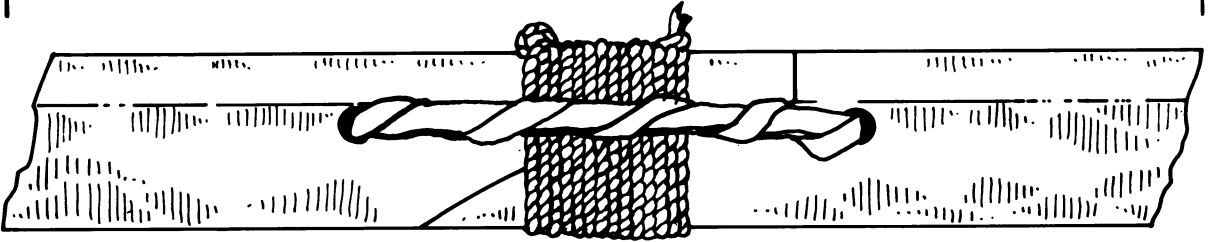
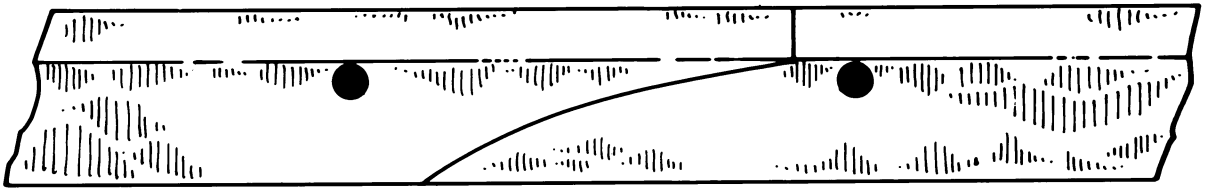

KEELSON SCARF JOINT LASHING

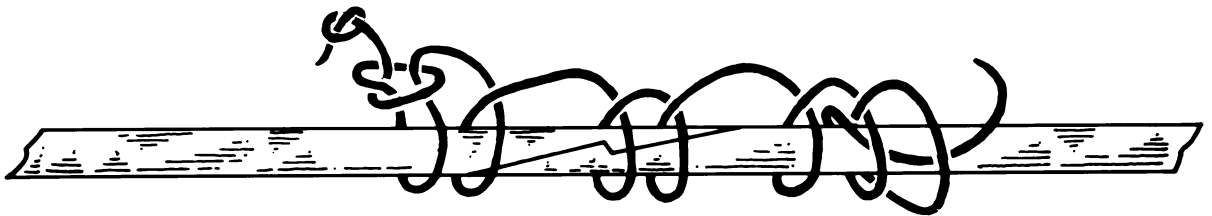

STRINGER SCARF JOINT LASHING

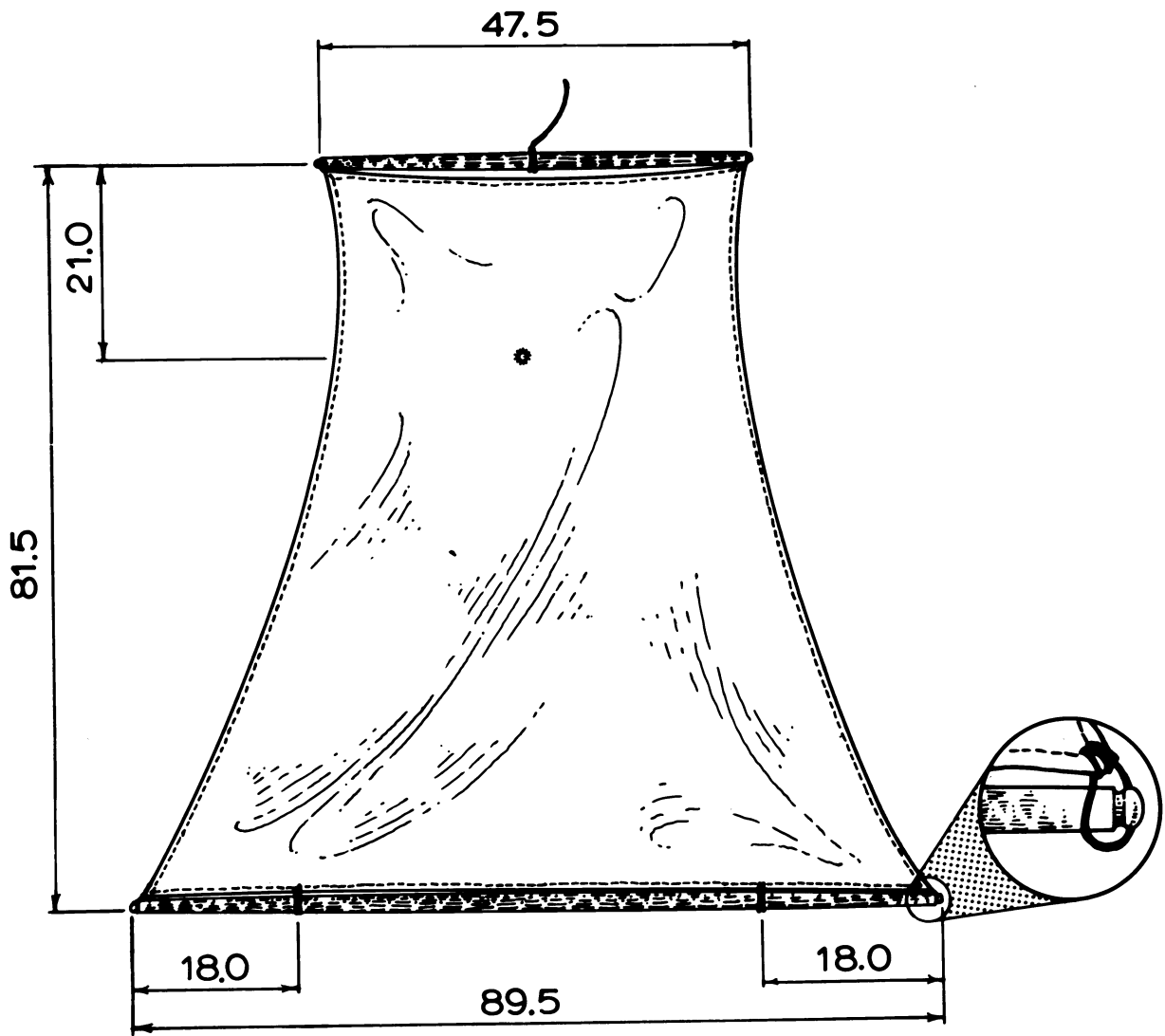

SAIL

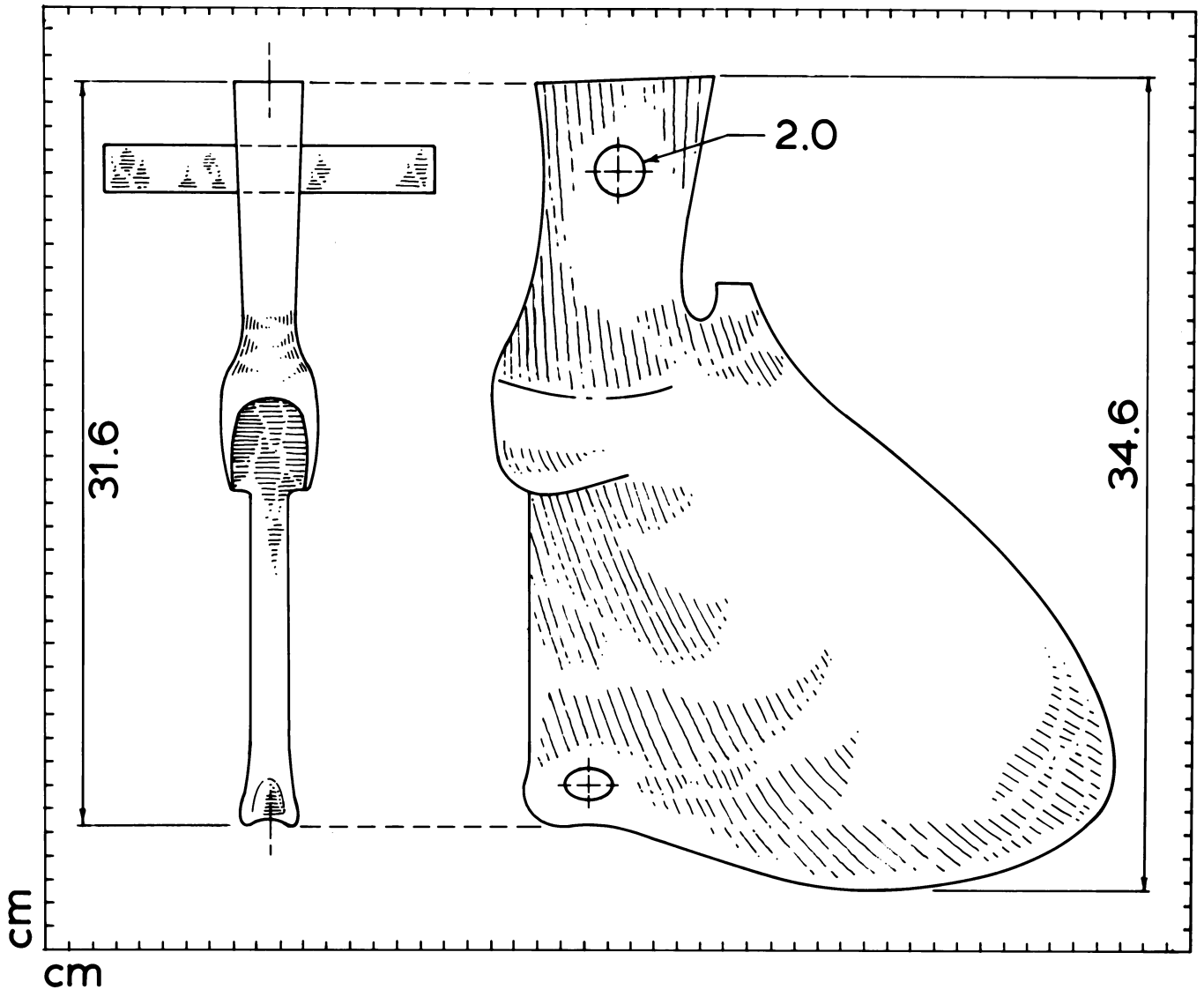

RUDDER

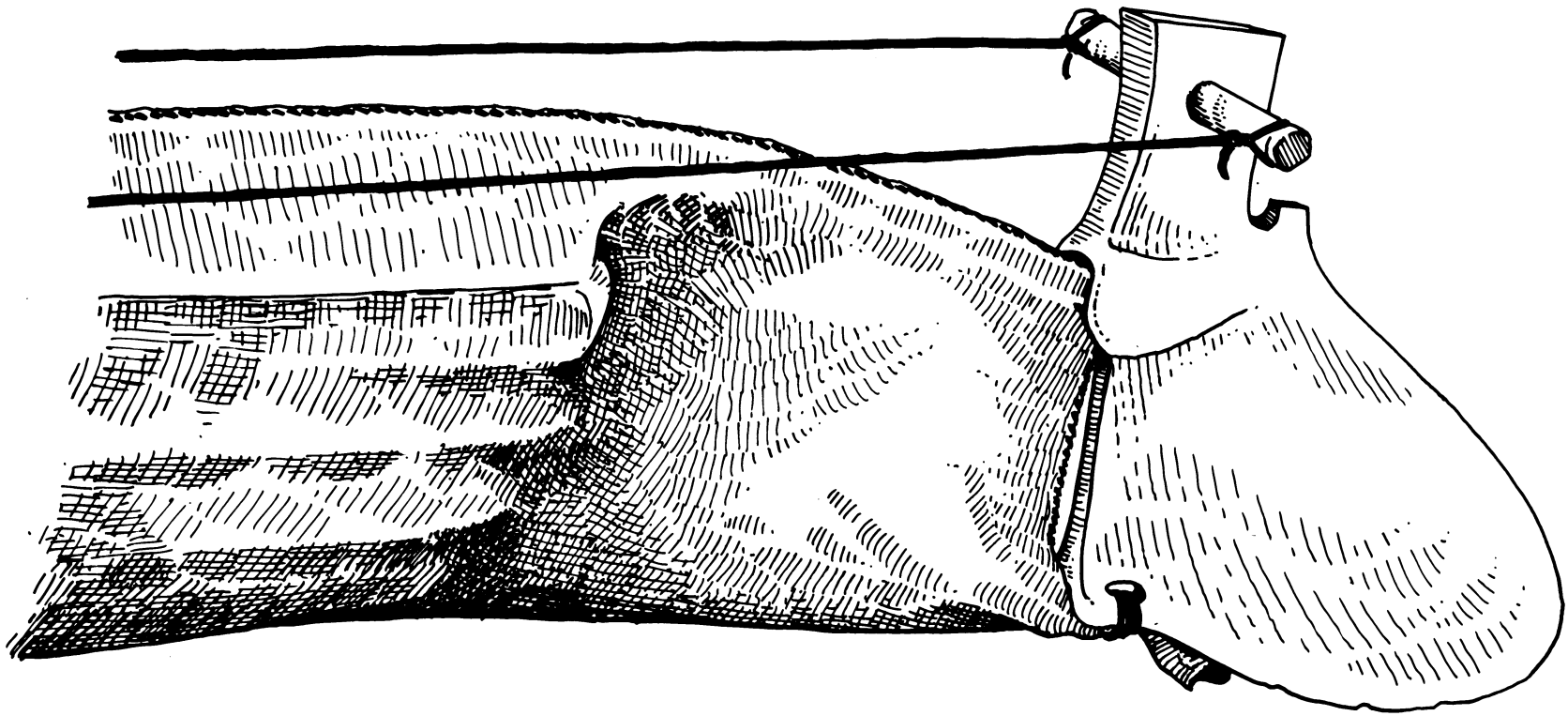

KAYAK RUDDER ATTACHMENT

